

# Design and Installation Guidelines

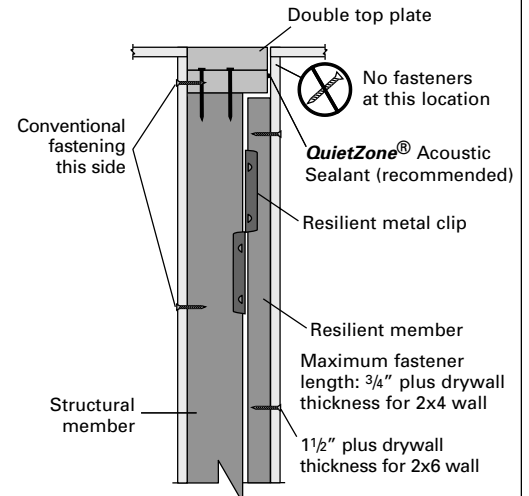

## 1 USA QuietZone® Acoustic Wall Framing

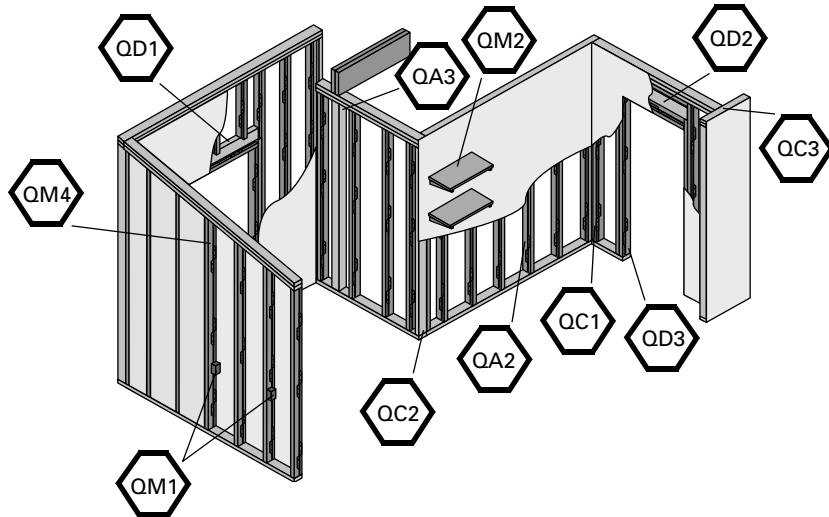

### DIMENSIONS

#### 2x4 Wall

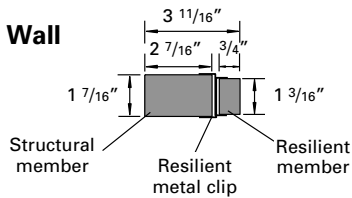

#### 2x6 Wall

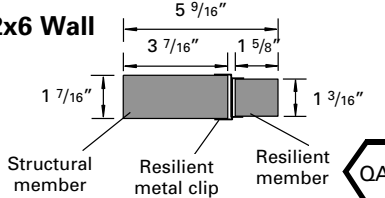

### SUPPORT COLUMNS

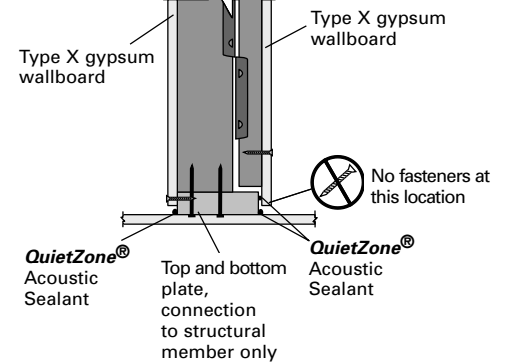
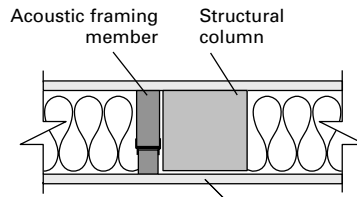

### ALLOWABLE DESIGN VALUES (100% LOAD DURATION) - STRUCTURAL MEMBER

QuietZone® Acoustic Wall Framing featuring Tembec Select Engineered Lumber (Structural Member) and Selectem™ LVL (Resilient Member)

Modulus of elasticity	E = 1.4 x 10 <sup>6</sup> psi
Bending at extreme fibre	F <sub>b</sub> = 875 psi
Compression parallel to grain	F <sub>c</sub> = 1150 psi
Compression perpendicular to grain	F <sub>cp</sub> = 425 psi
Shear parallel to grain	F <sub>v</sub> = 135 psi

Nail Design Values, Structural Member, Lateral and Withdrawl: Design as per National Design Specification for Wood Construction for Spruce Pine Fir species SG = 0.42

Nail Design Values, Resilient Member, Lateral and Withdrawl: Design as per National Design Specification for Wood Construction for Hem-Fir species SG = 0.43

Code evaluation for resilient member: NER-507

Values may be increased by a repetitive member factor (Cr) if applicable

Values may be increased by a load duration factor (Cd) if applicable

Values may be increased by a size factor (Cf)

QuietZone® Acoustic Wall Framing is to be used in "dry" service conditions only

QuietZone® Acoustic Wall Framing has no Preservative or Fire Retardant Treatment

# Design and Installation Guidelines

2

## QuietZone® Acoustic Wall Framing

### INSIDE CORNER

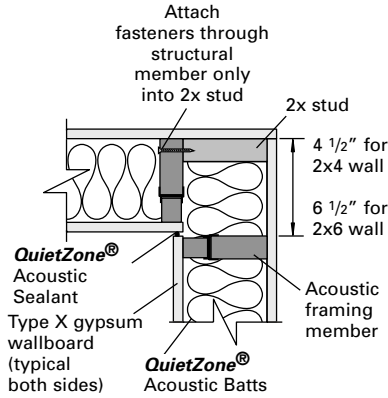

QC1

### OUTSIDE CORNER

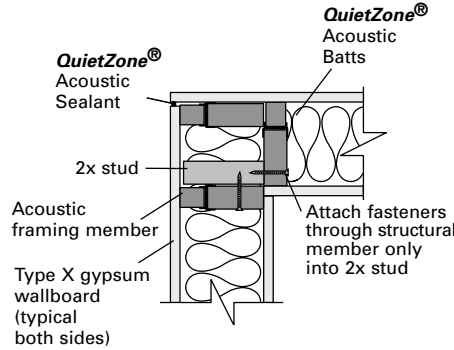

QC2

### QUIETZONE® TO STANDARD WALL CONNECTION

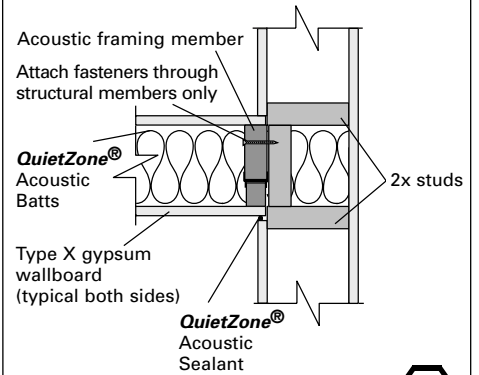

QC3

### LOW HEADER

(Install header flush to structural side of wall only)

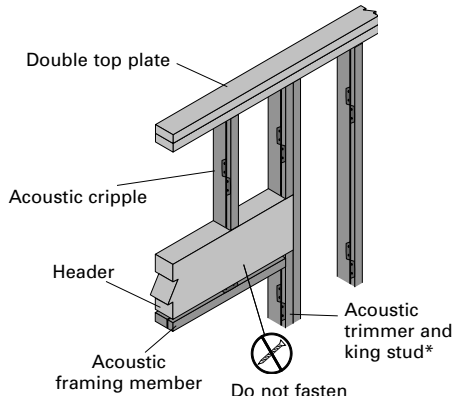

\*Additional trimmers and/or king studs may be required to support header reaction.

QD1

### HIGH HEADER

(Install header flush to structural side of wall only)

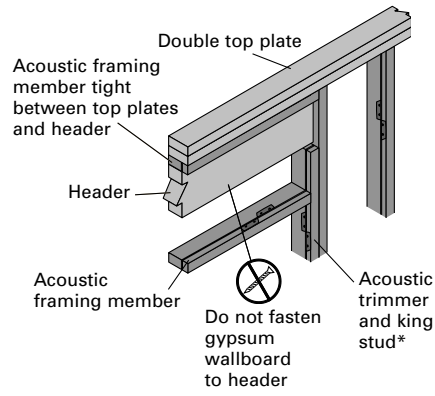

\*Additional trimmers and/or king studs may be required to support header reaction.

QD2

### DOOR ATTACHMENT

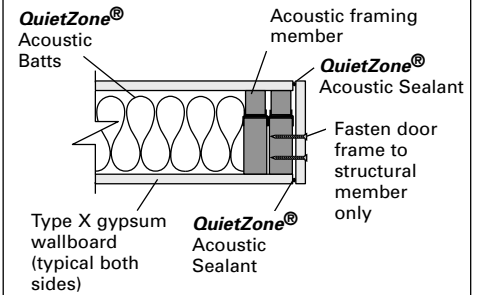

QD3

### ELECTRICAL BOXES

#### Resilient Side of Wall

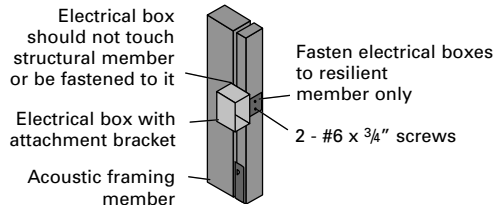
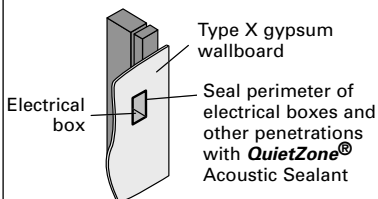

#### Structural Side of Wall

Electrical boxes should not be installed back to back on opposite sides of the wall. Plugs and switches should be spaced a minimum of 36" between each other and wall fixtures a minimum of 24" between each other.

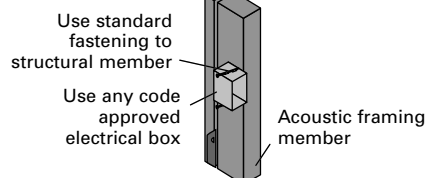

QM1

### SHELVES AND FIXTURES

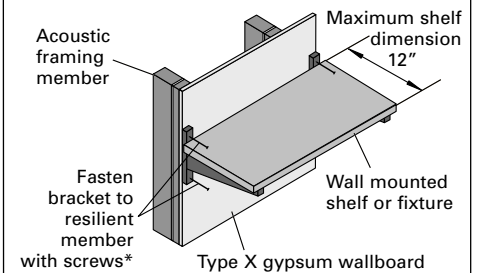

MAXIMUM WEIGHT OF FIXTURE ATTACHED TO RESILIENT MEMBER SHALL NOT EXCEED 40 LBS PER MEMBER FOR SHELF DIMENSIONS SHOWN ABOVE.

\* Fasteners should not extend to the structural member. Maximum fastener length:

2x4 wall - 3/4" + drywall thickness + thickness of bracket

2x6 wall - 1 5/8" + drywall thickness + thickness of bracket

QM2

# Design and Installation Guidelines

3

## QuietZone® Acoustic Wall Framing

### ALLOWABLE HOLES AND NOTCHES

#### 2x4 Walls

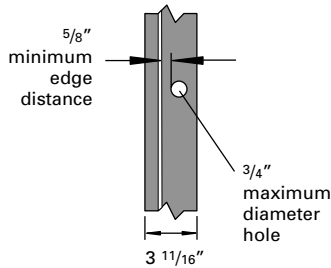

Holes shown may be cut anywhere along the length of the member, but no closer than 5/8" from the edge.

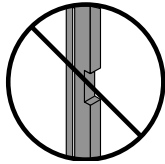

**NO NOTCHES** in the 2x4 wall assembly!

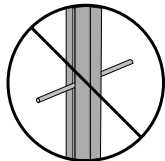

**DO NOT** run electrical wires or pipes through the gap between members for either 2x4 or 2x6 wall framing!

#### 2x6 Walls

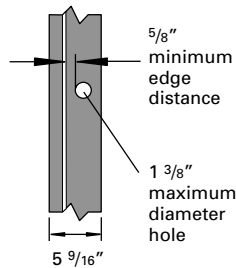

Notches shown may be cut in the 2x6 wall assembly anywhere except the middle 1/3 of the length of the member.

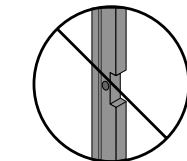
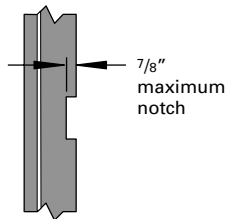

Notches and holes shall not occur in the same cross section!



### CUTTING NON-STANDARD LENGTHS

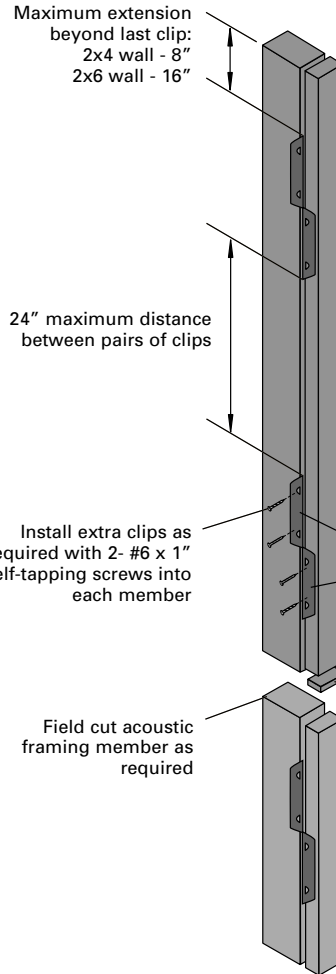

### GENERAL NOTES

- **QuietZone®** Acoustic Wall Framing is intended for interior walls only. Contact Jager Building Systems at 1-866-864-5710 for information on other applications.
- 2x4 **QuietZone®** Acoustic Wall Framing has load-bearing capabilities similar to 2x3 wood framing; see design tables for details.
- 2x6 **QuietZone®** Acoustic Wall Framing has load-bearing capabilities similar to 2x4 wood framing; see design tables for details.
- Screws are recommended for fastening drywall, shelves, and fixtures to **QuietZone®** Acoustic Wall Framing. Use caution if fastening drywall to resilient member using a nailgun.
- **QuietZone®** Acoustic Batts (15" or 23" width) will be required in the cavity space between wall framing sections spaced either 16" or 24" o.c. when using 2 x 4 & 2 x 6 **QuietZone®** Acoustic Wall Framing.
- **QuietZone®** Acoustic Batts fit between wood framing members with the flanges stapled to the sides of the **QuietZone®** Acoustic Wall Framing structural members.

**WARNING:** LACK OF PROPER BRACING, INSUFFICIENT WALL SYSTEM DESIGN OR FAILURE TO FOLLOW THE INSTRUCTIONS SET FORTH HEREIN COULD LEAD TO PROPERTY DAMAGE AND/OR SERIOUS BODILY INJURY. NEITHER OWENS CORNING NOR TEMBEC SHALL BE RESPONSIBLE FOR ANY DAMAGE, LOSS, COSTS OR EXPENSES RELATING TO ANY MISUSE OF THE PRODUCTS DESCRIBED ABOVE, OR ANY FAILURE TO ADHERE TO THESE INSTRUCTIONS.

### MULTIPLE LAYERS OF GYPSUM

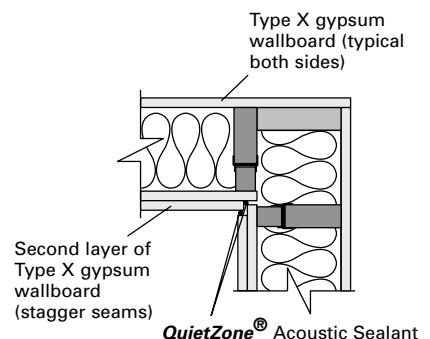

Apply **QuietZone®** Acoustic Sealant along corner of first layer of Type X gypsum wallboard before applying second layer of Type X gypsum wallboard.



# QuietZone® Acoustic Wall Framing

## Walls supporting one floor only

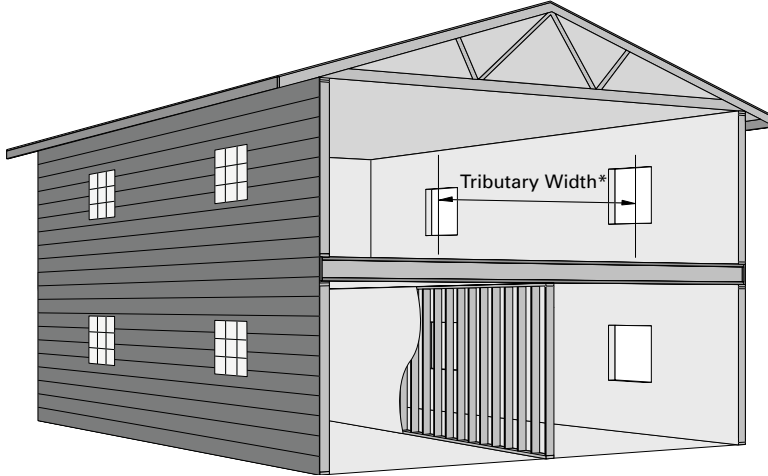

## Walls supporting attic framing only

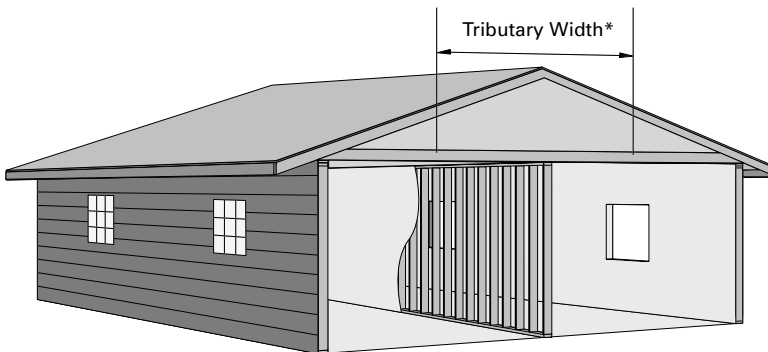

\*Tributary width is calculated as a percentage of the sum of the joist spans on either side of the wall:  
 simple span: 0.5 ft x (left span + right span)  
 continuous span: 0.625 ft x (left span + right span)

For more information on the QuietZone® Acoustic Wall Framing call Jager Building Systems at **1-866-864-5710**. For more information on other QuietZone® Products (QuietZone® Acoustic Batt & QuietZone® Acoustic Sealant) call **1-800-GET-PINK**, or visit [www.owenscorning.com](http://www.owenscorning.com).



INNOVATIONS FOR LIVING®

[www.owenscorning.com](http://www.owenscorning.com)  
**1-800-GET-PINK**



FOREST PRODUCTS GROUP

[www.tembec.com](http://www.tembec.com)

### Maximum Tributary Width\* (ft) One Floor Only

Member Nominal Size	Wall Height	Member Spacing	Floor Load (psf unfactored)	
			40LL + 10DL	40LL + 25DL
2x4	8'	16" o.c.	12	9
		24" o.c.	10	8
	9'	16" o.c.	9	7
		24" o.c.	---	---
	10'	16" o.c.	---	---
		24" o.c.	---	---
2x6	8'	16" o.c.	30	30
		24" o.c.	30	30
	9'	16" o.c.	30	26
		24" o.c.	30	24
	10'	16" o.c.	26	20
		24" o.c.	24	18
	12'	16" o.c.	15	12
		24" o.c.	13	10
	14'	16" o.c.	10	8
		24" o.c.	---	---

### Maximum Tributary Width\* (ft) Attic Framing Only

Member Nominal Size	Wall Height	Member Spacing	Attic Load (psf unfactored)
			20LL + 10DL
2x4	8'	16" o.c.	20
		24" o.c.	17
	9'	16" o.c.	15
		24" o.c.	12
	10'	16" o.c.	11
		24" o.c.	---
2x6	8'	16" o.c.	30
		24" o.c.	30
	9'	16" o.c.	30
		24" o.c.	30
	10'	16" o.c.	30
		24" o.c.	30
	12'	16" o.c.	26
		24" o.c.	22
	14'	16" o.c.	17
		24" o.c.	13

### Maximum Vertical Load (plf factored) Interior Walls Only

Wall Height	Stud Length	2x4 Wall			2x6 Wall		
		On-Center Spacing	12"	16"	24"	On-Center Spacing	12"
8'	92 5/8"	670	615	530	2230	2230	2090
9'	104 5/8"	495	445	365	1815	1725	1570
10'	116 5/8"	370	325	245	1425	1340	1200
12'	144"				865	790	665
14'	168"				580	515	395

Table is based upon:

- Type X gypsum wallboard applied to each side of the wall
- Interior lateral wall pressure of 5 psf