



System No. CW-D-1003

June 23, 2016

F Rating — 2 Hr

T Rating — 1/4 Hr

Linear Opening Width — 6 In. Max

Class II Movement Capabilities — 5% Vertical Shear (See Item 3)

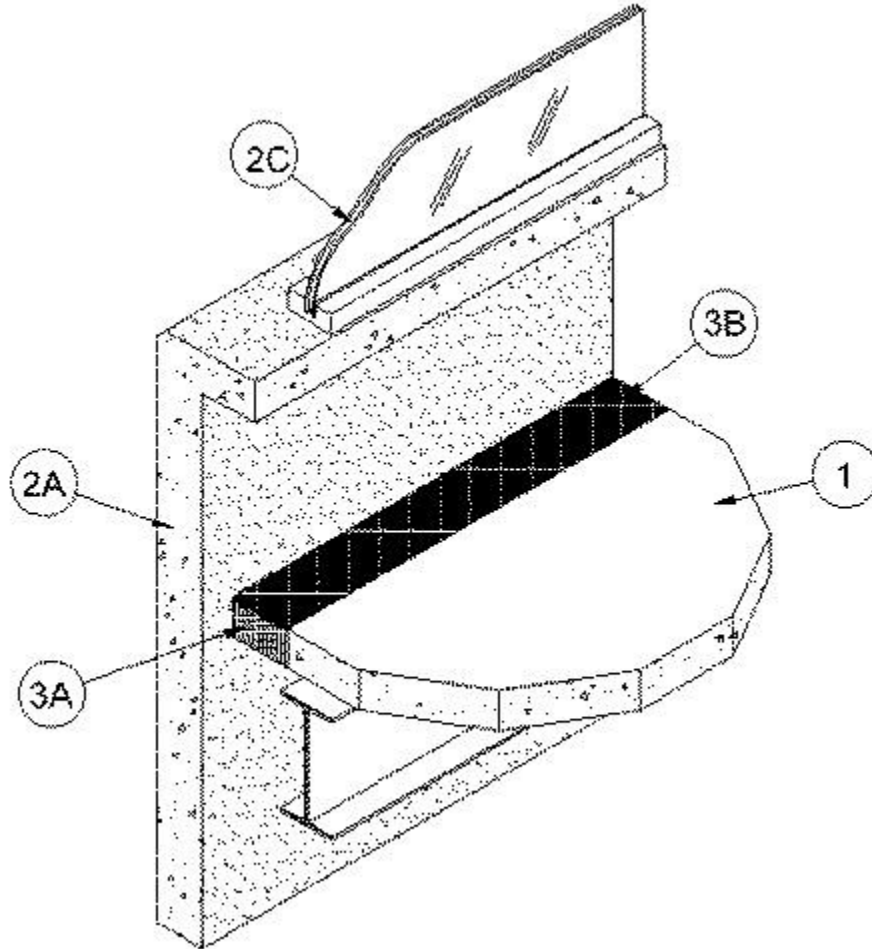

1. **Floor Assembly** — Min 4-1/2 in. thick steel-reinforced lightweight or normal weight (100-150 pcf) structural concrete. Floor assembly to be supported at perimeter edges by spandrel beams having a Restrained or Unrestrained Beam Rating of 2 hr.
2. **Curtain Wall Assembly** — The curtain wall assembly shall incorporate the following construction features:



Scan the QR code to request an Engineering Judgment.

THERMAFIBER, INC.
ONE OWENS CORNING PARKWAY
TOLEDO, OH 43659 USA
888-TFIBER1 [834-2371]
www.owenscorning.com/thermafiber



A. **Spandrel Panels** — Min 36 in. high by min 4 in. thick steel-reinforced lightweight or normal weight (100-150 pcf) structural concrete spandrel panels. Wall may also consist of min 4 in. thick steel-reinforced lightweight or normal weight concrete tilt-up panels with a min 36 in. vertical

separation between window openings. Panels provided with steel dead load anchors welded to steel reinforcing bars embedded in the concrete for attachment to the steel columns and spandrel beams. Panels also provided with steel lateral anchors or braces. The dead load anchors which are located in the linear gap between the concrete floor slab and the spandrel panel or tilt-up panel are to be spaced max 72 in. OC. The top of the dead load anchor is to be recessed min 1/2 in. from top surface of floor

B. **Joint System** — (Not Shown) — Vertical joints between spandrel panels or tilt-up panels to be protected using Joint System No. WW-S-0042

C. **Framed Window** — Metal framed window with nom 1/4 in. thick heat-strengthened glass. Sill of window to be min 6 in. above top of floor.

3. **Safing System** — Max separation between edge of floor assembly and concrete spandrel or tilt-up panel is 6 in. The safing system is designed to accommodate vertical shear movement of up to 5 percent of its installed width. The safing system shall incorporate the following construction features:

A. **Forming Material*** — Nom 4 in. thick mineral wool batt safing material to be installed between the concrete spandrel or tilt-up panel and the edge of the concrete floor slab. Safing material to be cut to a min 4-1/4 in. width and stacked to a thickness which is at least 25 percent greater than the width of the linear gap between the concrete spandrel or tilt-up panel and the edge of the concrete floor slab. The safing material is compressed and inserted cut-edge-first into the linear gap such that its top surface is recessed below the top surface of the floor assembly to accommodate the required thickness of fill material. A max of one tightly-butted seam is permitted between dead load anchors. An additional min 1/2 in. thick piece of mineral wool batt safing material to be installed to cover top surface of each dead load anchor.

THERMAFIBER/OWENS CORNING — SAF

B. **Fill, Void or Cavity Material*** — Min 1/4 in. thickness of fill material applied over top of forming material flush with the top surface of the concrete floor and lapping onto the concrete spandrel panel or tilt-up panel.

B1. **Fill, Void or Cavity Material*** — As an alternate to Item 3B, min 1/8 in. thickness of fill material applied over top of forming material flush with the top surface of the concrete floor and lapping onto the concrete spandrel panel or tilt-up panel.

HILTI CONSTRUCTION CHEMICALS, DIV OF HILTI INC — CFS-S SIL SL Sealant



Scan the QR code to request an Engineering Judgment.

THERMAFIBER, INC.
ONE OWENS CORNING PARKWAY
TOLEDO, OH 43659 USA
888-TFIBER1 [834-2371]
www.owenscorning.com/thermafiber